

Installationsanweisung Grant Lenkräder

NOT FOR USE ON AIRBAG EQUIPPED VEHICLES

GRANT

FORM #4

YOU MUST CUT GROUNDING SPRING ON ALL SIGNATURE SERIES HORN BUTTONS TO PREVENT A SHORT CIRCUIT - SEE REVERSE SIDE OF INSTRUCTION SHEET OR INSTRUCTIONS PROVIDED WITH STEERING WHEEL FOR EXACT PROCEDURE.

NOTE: THE KIT NUMBER 3288 POST COVER IS DESIGNED WITH THE HOLE PATTERN OFF CENTER TO LOOK THE BEST ON THIS COLUMN WHEN THE WHEEL IS STRAIGHT. YOU MAY NOTICE A SLIGHT GAP WHEN TURNING THE WHEEL. THIS IS NORMAL!

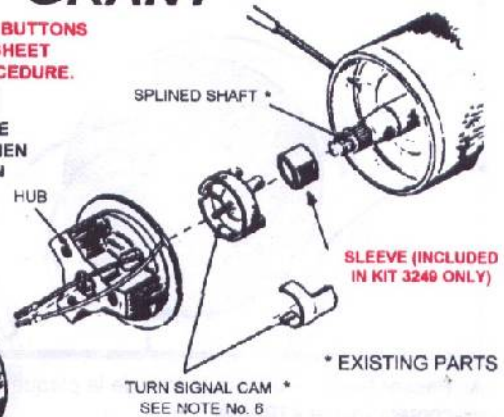
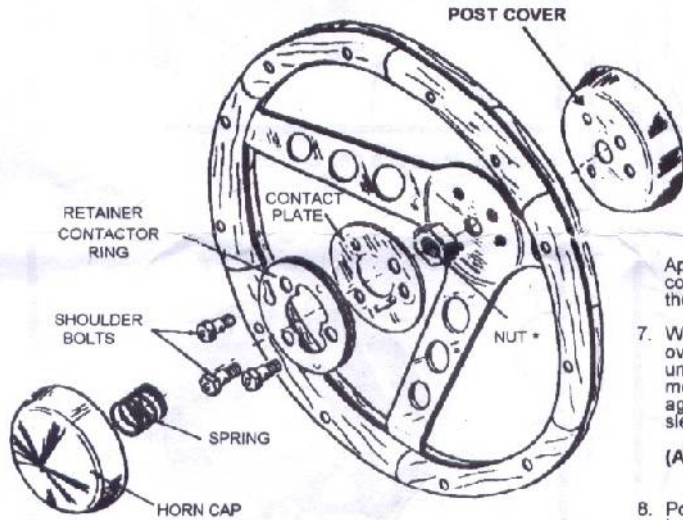

SHOWN: TYPICAL CLASSIC/CHALLENGER INSTALLATION

Apply grease from enclosed capsules to cover the copper contact surface on custom hub. This will reduce wear on the parts and does not interfere with the electrical circuit.

- When using kit number 3249, install tubular metal sleeve over shaft. **NOTE:** Sleeve should fit freely and slide down until it bottoms. On some models the plastic turn signal mechanism may prevent it from bottoming or fit snugly against its sides. If either condition exists, do not use sleeve, it is not required.

(A) Note Ford special instruction notice on reverse side of this form regarding stub on end of shaft.

- Position hub on splined shaft observing that "top" is located in accordance with the mark which you made in step No. 4.
- Position post cover and wheel using the three shoulder bolts provided, but do not tighten them.

NOTE: When using kit 3294 on older Fords. If there is a gap between the post cover and the column, there is an easy adjustment that can be made. Loosen the bolts under the dash that hold the column in position, move the column housing up or down as needed leaving about a 1/8" gap and then retighten these bolts securely.

- Check wheel for position, and if correct, install the wheel retainer nut and tighten securely.
- Remove shoulder bolts. See reverse side for pictorial representation of the remaining assembly procedures.

GENERAL NOTES

When tightening the three shoulder bolts, please keep in mind that they are not meant to hold the wheel to the hub, but only to position the wheel to the hub. The wheel retainer nut, if properly tightened, will firmly hold the hub/wheel assembly to the steering shaft. It is important that excessive torque not be applied to these bolts, or the contact plate may fracture or distort, causing a possible malfunction in the horn contact mechanism. Not to mention this may cause damage to the threads in the hub.

TORQUE REQUIREMENTS

SHOULDER BOLTS 10-12 FT/LBS
STEERING SHAFT NUT 25-30 FT/LBS

- Point wheels straight ahead and disconnect battery or pull horn fuse before starting removal of the old wheel so horn won't short out and blow during installation.
- Remove horn mechanism. This is normally done by one or more of the following steps:
 - Press down on horn cap or ring and turn.
 - Remove emblem cap from its snapped-in condition by grasping it and pulling toward you, or pry loose.
 - Horn ring and emblem may be secured by screws which are concealed in rear side of wheel spokes.

If one of the above operations has not removed all of the horn parts, it will have exposed the remaining screws to permit easy removal of the balance of such parts.

- Remove nut or bolt holding wheel to shaft.
- Mark shaft as to which is the top of the wheel.
- With conventional puller, (or GRANT puller 5891), use the two tapped holes which you will find in the hub of old wheel to pull off the steering shaft.

If a puller is not available, you may improvise an efficient one to do the job. By drilling two holes of the proper size in a short steel bar and using two screws of the proper length, you can tighten them and pull the old wheel very easily.

- If your old wheel has a turn indicator cam, remove this part and reinstall in the same position on back of custom hub. Generally this part is affixed to the steering wheel with screws or clamped on by spring tension. **NOTE: Some cams are molded into the old wheel and are not removeable, use roll pin(s) provided in kit for these applications. See enclosed roll pin instructions.**

- Position spring on nut. You may find tape a help. Place horn cap in position by aligning dimples with reliefs in fiber material and push until dimples pass fiber. Turn cap left or right until tight (1/4"-1/2").

- Reconnect battery or replace fuse and enjoy your new wheel.

On the Web: www.grantproducts.com
Rev. 9/99 by J.F. 97504-00-01

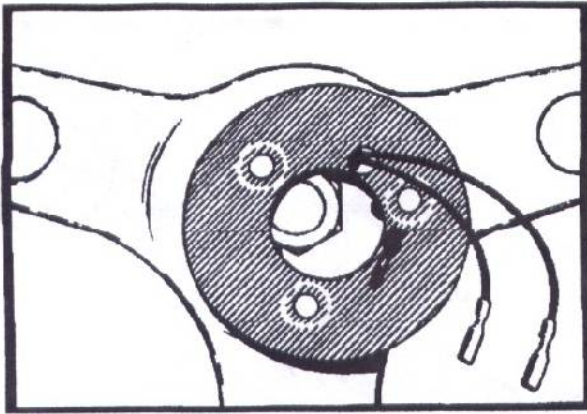

A. Thread contact plate (part No. 10031) over wires.

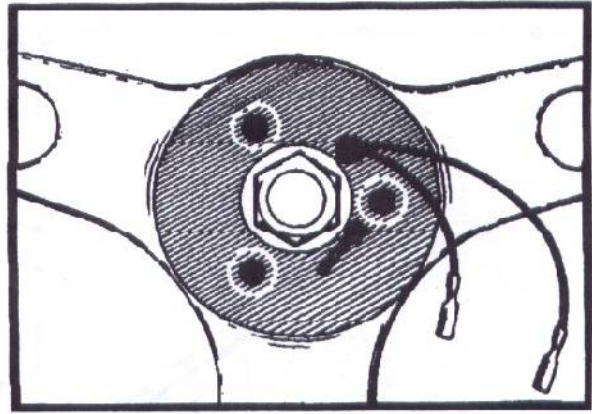

B. Position bolt holes to match.

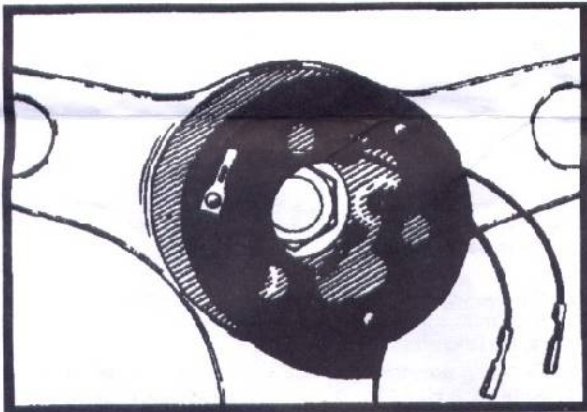

C. Next thread retainer contactor so that fibre is towards you.

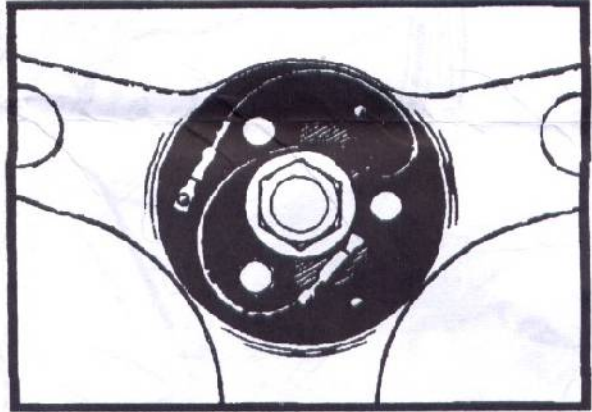

D. Replace shoulder screws and tighten then plug in both wire leads.

FORD SPECIAL INSTRUCTIONS SUPPLEMENT

Most Ford vehicles beginning in 1966 have a small unused stub protruding from the end of the steering shaft, it will be necessary to hacksaw this stub off for proper horn clearance on Classic and Challenger model wheels. Mount the adapter hub and shaft nut and cover the steering column with a rag before sawing. Remove shaft nut and proceed with installation.

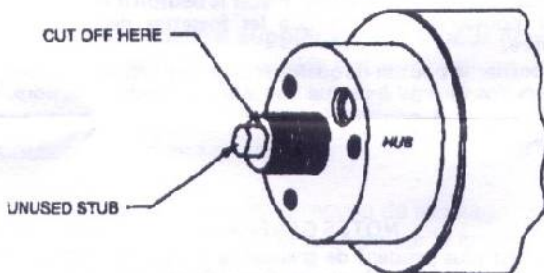

ALL SIGNATURE WHEELS MUST PERFORM THE FOLLOWING HORN BUTTON MODIFICATION.

Cut off external portion of spring

(This wire must not make contact with steering wheel). To do this, pull spring out slightly and cut at the point where it goes back into button housing with wire cutters. Then push back in slightly so that it is completely within plastic housing.

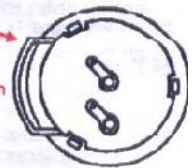

OUR LIMITED WARRANTY

We warrant this product for ninety (90) days from the date of original purchase to be free from defects in materials and workmanship. If, during this period, the product fails under normal usage because of a manufacturing defect, then we will replace or repair the item. To obtain repair or replacement under the terms of this warranty, notify us at 700 Allen Avenue, Glendale California 91201. Proof of purchase and date of purchase are required to validate warranty.

All implied warranties, including warranty of merchantability, are limited to this same ninety-day period from date of original purchase. We are not liable for any direct or consequential loss or property damage arising from any use of this product. This warranty gives you specific legal rights, and you may also have other rights which vary from state to state. Offer good in U.S.A. and Canada only.

IMPORTANT

FOR YOUR OWN SAFETY, DO NOT USE THIS WHEEL FOR ANY COMPETITIVE OR COMMERCIAL RACING PURPOSES RACING DOES NOT CONSTITUTE NORMAL USAGE AND THEREFORE MAKES THIS WARRANTY VOID

**MUSTANGER WHEEL MODELS 963/966/968
HORN OPERATION SUPPLEMENT**

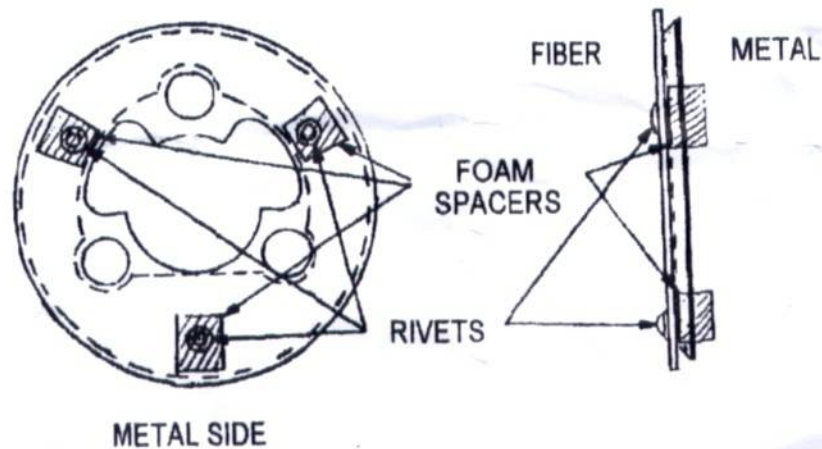

DO NOT USE THE HORN BUTTON SPRING OR BROWN RETAINER CONTACTOR RING PROVIDED IN YOUR INSTALLATION KIT.

USE THE RETAINER CONTACTOR RING PROVIDED WITH THE WHEEL (NOT ONE PROVIDED IN KIT). ATTACH THE THREE FOAM SPACERS PROVIDED BY SIMPLY PEELING THE PAPER TAPE FROM THE FOAM EXPOSING AN ADHESIVE AND PRESS THIS ADHESIVE SIDE DOWN FIRMLY OVER THE RIVET AREA AS SHOWN ABOVE. (TAKE CARE THAT FOAM DOES NOT COVER OUTER EDGE OF METAL RING OR DIMPLES STAMPED INTO METAL PLATE).

FOLLOW THE REST OF THE DIRECTIONS ON MAIN INSTRUCTION SHEET BUT ELIMINATE THE HORN SPRING INSTALLATION.

INSTALL HORN BUTTON BY ALIGNING SO THAT THE LOGO IS STRAIGHT WITH THE WHEEL THEN PRESS DOWN **FIRMLY** ONTO RETAINER CONTACTOR RING. DO NOT TURN BUTTON ONCE IT IS PRESSED ONTO RING. ENJOY YOUR NEW GRANT CUSTOM STEERING WHEEL.

INSTRUCTION SUPPLEMENT

READ BEFORE ASSEMBLING WHEEL

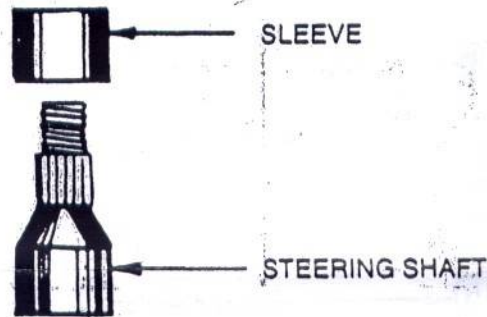

AFTER EXISTING STEERING WHEEL AND ASSOCIATED HARDWARE HAVE BEEN REMOVED AS INDICATED IN YOUR INSTRUCTION SHEET, PLACE SLEEVE OVER STEERING SHAFT AS SHOWN ABOVE.

IMPORTANT NOTE

SLEEVE SHOULD FIT **FREELY** OVER SHAFT AND SLIDE DOWN UNTIL IT BOTTOMS.

ON SOME MODELS THE PLASTIC TURN SIGNAL CANCELING MECHANISM PREVENTS THIS SLEEVE FROM BOTTOMING OR FITS SNUGLY AGAINST SIDES OF SLEEVE. IF EITHER OF THESE CONDITIONS EXIST, **DO NOT USE SLEEVE**, IT IS NOT REQUIRED.

CONTINUE WITH INSTRUCTIONS.